



CAST STEEL Y STRAINER 150LB/ 300LB

Applicable Standards:

- STEEL STRAINER, ASME B16.34
- FACE TO FACE, ASME B16.10
- END FLANGES, ASME B16.5
- BUTTWELDING ENDS, ASME B16.25
- INSPECTION AND TEST, API 598

Design descriptions:

- Y-PATTERN TYPE
- BOLTED BONNET CAP WITH DRAIN PLUG
- PERFORATED STAINLESS STEEL SCREEN
- STRAINER DENSITY 100 MESH DESIGN
- FULL RANGE OF STRAINER DENSITY
- RENEWABLE STRAINER DENSITY
- FLANGED OR BUTTWELDING ENDS

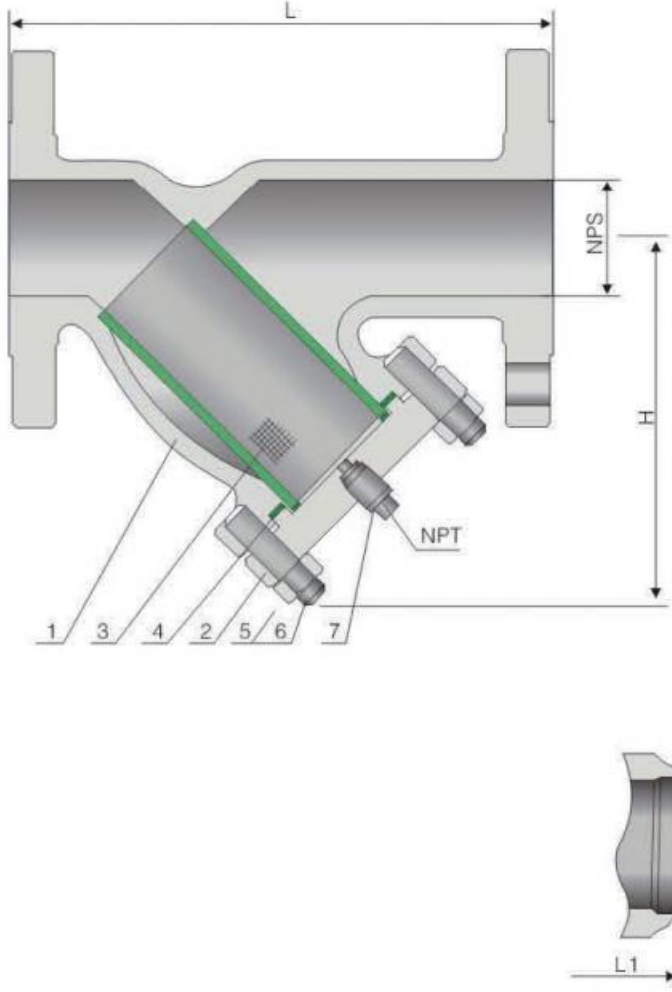

Materials of parts

No	Part Name	ASTM Materials		
		Carbon Steel	18Cr-9Ni-2Mo	Carbon Steel
1	Body	A216-WCB	A351-CF8M	A352-LCB
2	Bonnet Cap	A216-WCB	A351-CF8M	A350-LCB
3	Screen	A240-304	A240-316	A240-304
4	Bonnet Gasket	Graphite+304 ¹⁾	PTFE	Graphite+304 ¹⁾
5	Bonnet Stud	A193-B7	A193-B8	A320-L7
6	Bonnet Stud Nut	A194-2H	A194-8	A194-7
7	Drain Plug	A276-410	A276-316	A276-410

Note: 1) spiral wound construction

Percentage of open area

MESH	A SWG	B m/m	C m/m	D %
5	20	0.914	4.166	67.3
10	22	0.711	1.829	51.8
20	28	0.356	0.914	51.8
30	32	0.274	0.572	45.7
40	36	0.193	0.442	48.4
50	37	0.172	0.336	43.6
60	38	0.152	0.271	41.0
80	40	0.122	0.195	37.8
100	42	0.102	0.152	35.8
120	43	0.092	0.119	31.8
150	45 1/2	0.066	0.103	37.1
180	46 1/2	0.053	0.088	38.9
200	47	0.051	0.076	35.8
250	48	0.040	0.062	37.7
300	48	0.039	0.044	27.6

Even the mesh* is same:
open area is not always same
due to the diameter of wire.
The details of wire as follows:

- A: Number of Wire
- B: Diameter of Wire
- C: Width of Opening
- D: Percentage of OPEN AREA

Dimensional datas

NPS	DN	L/L1 (RF/BW)		H	PLUG (NPT)	WT (KG)		L/L1 (RF/BW)	H	PLUG (NPT)	WT (KG)				
ANSI Class 150Lb													ANSI Class 300Lb		
1/2	15	5.50	140	3.38	87	1/8	2.1	0.8	5.50	140	3.38	87	1/8	2.5	1.2
3/4	20	6.00	152	4.12	105	1/2	2.3	1.2	6.00	152	4.12	105	1/2	3.4	1.8
1	25	6.50	165	4.50	114	1/2	3.1	1.4	6.50	165	4.50	114	1/2	4.2	2.6
1 1/2	40	8.00	203	6.12	156	1/2	6.2	3.7	8.00	203	6.12	156	1/2	8.6	4.8
2	50	9.00	229	7.12	181	1/2	9.7	6.7	9.00	229	7.12	181	1/2	11.12	8.2
2 1/2	65	11.00	279	10.25	259	3/4	23.5	16.5	11.00	279	10.25	259	3/4	29	20
3	80	12.50	318	11.50	293	3/4	28	22	12.50	318	11.50	293	3/4	38	27
4	100	14.50	368	12.75	324	3/4	37	28	14.50	368	12.75	324	3/4	57	39
6	150	18.50	470	17.62	448	3/4	67	59	18.50	470	17.62	448	3/4	105	74
8	200	23.50	597	21.00	535	3/4	91	78	23.50	597	21.00	535	3/4	176	131
10	250	26.50	673	27.12	690	1	135	113	26.50	673	27.12	690	1	230	164
12	300	30.50	775	30.75	780	1	168	151	30.50	775	30.75	780	1	360	268
in	mm	in	mm	in	mm	in	RF	BW	in	mm	in	mm	in	RF	BW